

Military Silicon Power Rectifier

1N1202A–1N1206A, 1N3671A–1N3673A

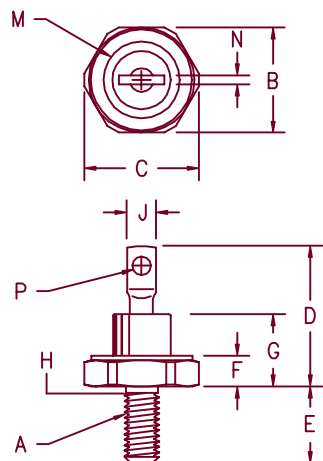

Notes:

1. 10–32 UNF3A
2. Full threads within 2 1/2 threads
3. Standard Polarity: Stud is Cathode
Reverse Polarity: Stud is Anode

Dim.	Inches		Millimeter		Notes
	Minimum	Maximum	Minimum	Maximum	
A	---	---	---	---	1
B	.424	.437	10.77	11.10	
C	---	.505	---	12.83	
D	---	.800	---	20.32	
E	.422	.453	10.72	11.51	
F	.075	.175	1.91	4.44	
G	---	.405	---	10.29	
H	.163	.189	4.15	4.80	2
J	.100	.140	2.54	3.56	
M	---	.350	---	8.89	Dia
N	.020	.065	.510	1.65	
P	.070	.100	1.78	2.54	Dia

D0203AA (D04)

- Available in JAN, JANTX and JANTXV
 - MIL-PRF-19500/260
 - Glass passivated die
 - Glass to metal seal construction
 - 240 Amps surge rating
- V_{RRM} to 1000 volts

Standard	Microsemi Catalog Number	Reverse	Peak Reverse Voltage
1N1202A	1N1202A	1N1202RA	200V
1N1204A	1N1204A	1N1204RA	400V
1N1206A	1N1206A	1N1206RA	600V
1N3671A	1N3671A	1N3671RA	800V
1N3673A	1N3673A	1N3673RA	1000V

Electrical Characteristics		
Average forward current	$I_{F(AV)}$ 12 Amps	$T_C = 150^\circ\text{C}$, half sine wave, $R_{\theta JC} = 2.0^\circ\text{C/W}$
Maximum surge current	I_{FSM} 240 Amps	8.3ms, half sine, $T_C = 200^\circ\text{C}$
Max I^2t for fusing	I^2t 240 A ² s	
Max peak forward voltage	V_{FM} 1.35 Volts	$I_{FM} = 38\text{A}; T_J = 25^\circ\text{C}^*$
Max peak reverse current	V_{FM} 2.30 Volts	$I_{FM} = 240\text{A}; T_J = 25^\circ\text{C}$
Max peak reverse current	I_{RM} 5 μA	$V_{RRM}, T_J = 25^\circ\text{C}$
Max peak reverse current	I_{RM} 1.0 mA	$V_{RRM}, T_J = 150^\circ\text{C}$
Max Recommended Operating Frequency	10kHz	

*Pulse test: Pulse width 300 μsec . Duty cycle 2%

Thermal and Mechanical Characteristics		
Storage temperature range	T_{STG}	-65°C to 200°C
Operating case temp range	T_C	-65°C to 150°C
Maximum thermal resistance	$R_{\theta JC}$	2.0°C/W Junction to Case
Mounting torque		15 inch pounds maximum
Weight		.16 ounces (5.0 grams) typical

MILITARY

1N1202A-1N1206A, 1N3671A-1N3673A

Figure 1
Typical Forward Characteristics

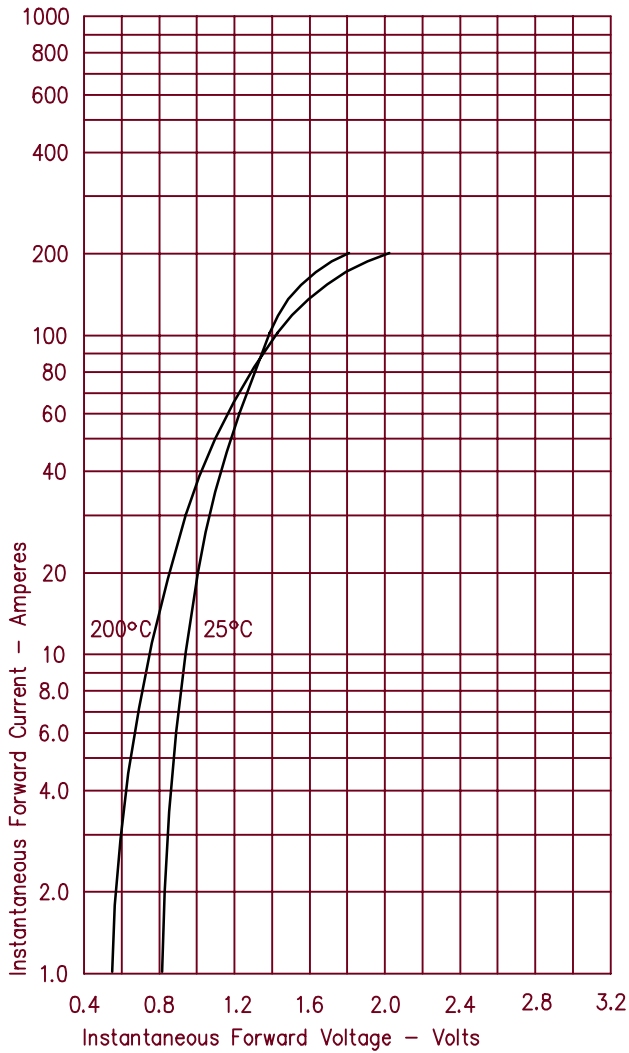

Figure 3
Forward Current Derating

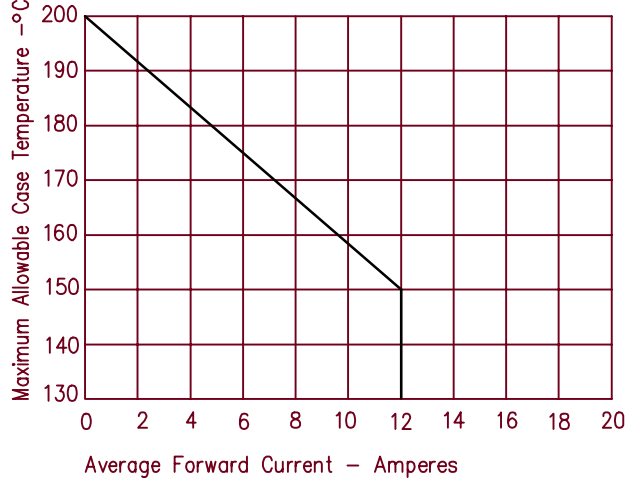

Figure 5
Transient Thermal Impedance

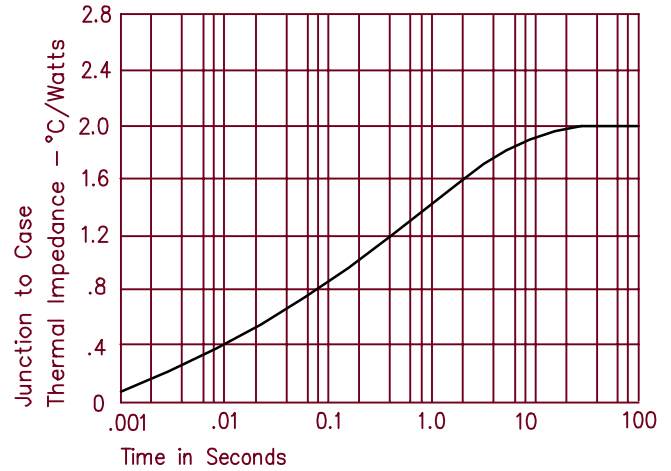

Figure 2
Typical Reverse Characteristics

