

Modline[®] 4

Noncontact Temperature Measurement for Industrial Applications



Modline 4 Highlights

Features

Rugged, compact and self-contained—the Modline 4 is designed and built for long, trouble-free service in harsh environments and is packaged in a sealed, cast aluminum NEMA 4 rated housing.

Stable drift-free operation

The Modline 4 DC operation has no moving parts—which guarantees a stable performance. The solid state electronics incorporates a chopper-stabilized amplifier which assures long term, accurate drift-free operation and the 4-20 mA high level current output assures reliable signal transmission over long lines.

Versatile, easy-to-install two-wire transmitter

The Modline 4 requires two wires, a power supply (range of 16 to 40 Vdc) and an installed compatible output (recording or control instrument) to complete the instrument system loop.

The two-wire operation simplifies the installation, operation and maintenance of the infrared thermometer. Screw terminals allow easy and secure wire hook ups. The digital emissivity control allows adjustments in 0.01 increments and a response time adjustment pot (potentiometer) lets you select values from 0.15 to 10 seconds to match any requirements.

The loop voltage is provided by the power supply. The loop current is determined by the Modline 4 instrument ordered and is calibrated to provide a linear output of 4 to 20 mA. Instruments within the current loop are supplied with a current proportional to the temperature span of the transmitter (20 mA at full scale and 4 mA at zero scale).

A number of instruments can be placed within the series current loop—provided that the total voltage drop for each instrument does not exceed the total loop voltage. There are six different spectral responses for a wide variety of application processes and the Modline 4 flanges make it easy to mount accessories in hostile environments.

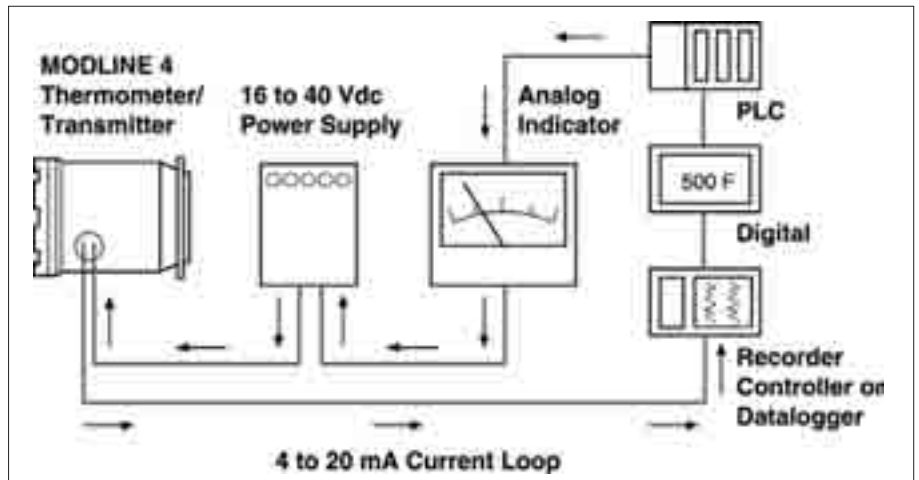

Modline 4 two-wire transmitter diagram

Specifications

Accuracy

Within 0.75% of full scale temperature or 1.7°C (3°F), whichever is greater

For the 22 series and 44-06C/44-10F: within 1.0% full scale or 2.8°C (5°F), whichever is greater.

For the 43 series: ambient temperature transients of 10°C (20°F) will cause some errors in reading until sensor is stabilized—allow 15 minutes for warm-up.

Repeatability

0.3% of full scale temperature.

For the 22 series: 0.5% full scale

Response Time

(to 95% of any change in input)

Continuously adjustable from approximately 0.15 to 10 seconds.

For the 43 series: set to 10 seconds for temperatures from 150°C (300°F) or lower.

Emissivity Range

Adjustable from 0.10 to 0.99 in 0.01 increments.

For the 43 series: minimum emissivity setting is 0.9 for all temperatures 150°C (300°F) or lower and 0.5 for temperatures above 150°C (300°F).

Peak Picker Option

Decay rate adjustable from 15 seconds to 30 minutes (approximately) for full scale decay. **Note: Peak picker is a standard feature for 22 series instruments.**

Power Supply/Load Requirements

Input voltage: 24 Vdc nominal

Input voltage range:

16 Vdc minimum to 40 Vdc maximum

Max. load resistance:

≤ 1 ohm at 16 Vdc; 400 ohms at 24 Vdc;

1200 ohms at 40 Vdc

Output Current

4 to 20 mA_{dc}

Temperature Coefficient

≤ 0.015% of span per °F change from nominal value of 77°F over a range of 32 to 150°F; ≤ 0.027 of span per °C change from nominal value of 25°C over a range of 0 to 66°C. **For the 43 series:** ≤ 0.05% of span per °F change from nominal value of 77°F over range of 32 to 150°F; ≤ 0.09% of span per °C change from nominal value of 25°C over range of 0 to 66°C. **For the 22 series:** ≤ 0.20% of span per °F change from nominal value of 77°F over range of 32 to 130°F; ≤ 0.035% of span per °C change from nominal value of 25°C over range of 0 to 55°C.

Ambient Temperature Range

32 to 150°F/0 to 66°C (without water cooling); 32 to 400°F/0 to 200°C (with water cooling). **For the 22 series:** 32 to 130°F/0 to 55°C (without water cooling).

Sensor Humidity

Limited from 10 to 90% non-condensing distance.

Environmentally-sealed Housing

Aluminum casting rated NEMA 4, IP56

Optical/Mechanical Alignment

Optical axis is within one degree of mechanical center line (within 0.2 inches per foot separation distance/17mm per meter separation distance).

For the 22 series: optical axis is within two degrees of mechanical center line (within 0.4 inches per foot/33mm per meter) separation distance.

Sensing Head Weight

2.6 lbs./1.2kg; 20lbs/9.25kg (with optional water cooling enclosure).

Accessories

Power supply

The Ircon® 24 VDC power supply is capable of powering up to ten Modline 4 units. The rugged, sealed package can be chassis-mounted or back panel-mounted using 4 tapped holes (factory provided). The screw terminals permit secure wiring. A current-limiting circuit protects the power supply in case of a short circuit. Model #PS-4-0/1 specifications:

Output voltage: 24 V, ±1%

Output current: 350 mA

Ambient temperature range:

-20 to 70°C (-4 to 158°F)

I/O isolation voltage: 1500V RMS

Resistance: 100 meg ohms

Power: 115/240 V, 50/60 Hz



Power supply

TV-View Meter

The TV-View digital indicator is powered by 110 or 220 Vac power. The display is programmable to work with Modline 4 sensors in both degree F and degree C. The indicator is NEMA 4 rated, IP65, with a sealed front bezel.



Temp View meter

Options

Water-Cooling Enclosure and Air Purge

Water flow of 10 to 20 gallons per hour at temperatures of 32°C (90°F) is sufficient for most applications. When the case temperature of the instrument is expected to exceed 66°C (150°F) due to ambient conditions, the WA-3 water cooling accessory gives a uniform temperature, isolates the transmitter electronics from thermal influence and permits operation in ambient temperatures up to 85°C (180°F). The EE-2 permits operations in ambients up to 200°C (400°F). The Ircon AA-3 air purge accessory is recommended when the environment contains smoke, particles,

steam and other impurities. A flow of clean, dry industrial air will keep the optics clear under most industrial conditions.

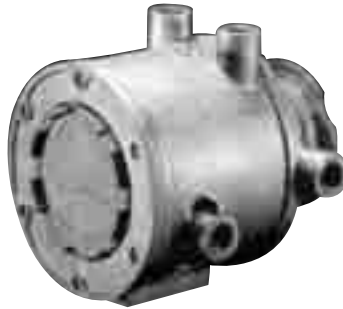

EE-2 Water-cooling enclosure

Peak Picker

The peak picker option provides circuitry which responds to the highest instantaneous temperature value and holds this signal through an adjustable slow decay rate.

The peak picker option is necessary if the sight path in your process is interrupted by smoke or steam (between the instrument and the target) or if the target moves in and out of view of the instrument.



Peak Picker

Swivel Mounting Base

The SB-1 swivel mounting base lets you aim the line of sight. You can tilt, swivel and lock the mounting base in place.

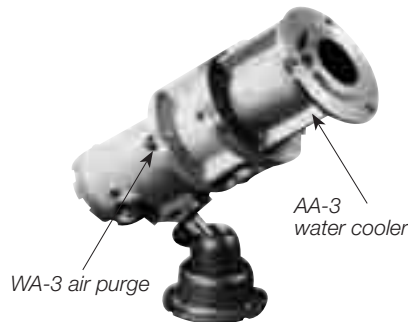

Air purge, water cooling and swivel base mounting accessories

Note: You cannot use the WA-3 and AA-3 together with models 43-04F or 43-02C because the cone vision is obstructed and would cause errors in reading. However, they can be used individually.

Optical Characteristics

Spot Size vs Separation Distance

The sensor responds to infrared radiation in an area indicated by the cone of vision. It will measure the target temperature within that cone. The spot size is the diameter of the cone at a particular separation distance.

Optical Characteristics Reference

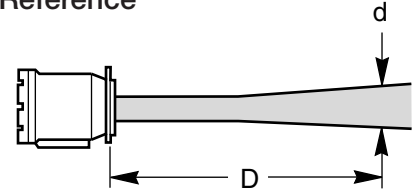

Note: above diagram not to scale

d=Spot size

D=Separation distance

Note: 43 series available in standard resolution only.

*Please refer to note below formula at bottom of page.

Spot Size vs Optical Resolution Chart

STANDARD RESOLUTION			
D (inches)	d (inches)	D (mm)	d (mm)
0 to 15	1.0	0 to 380	25
20	1.7	500	41
30	3.0	700	67
50	5.6	1,000	106
70	8.2	1,500	171
100	12.0	2,000	236
150	13.0	3,000	366
200	25.0	5,000	626
300	38.0	7,000	886
500	64.0	10,000	1,280
700	90.0	15,000	1,930
	123.0	20,000	2,580

Standard Resolution Formula*

If D > 15 inches or 380mm then:

$$d \text{ (inches)} = 0.13 (D \text{ inches} - 15) + 1$$

$$d \text{ (mm)} = 0.13 (D \text{ mm} - 380) + 25$$

Example:

$$\text{If } D = 45 \text{ inches, then } d = 0.13 (45-15) + 1$$

$$= 0.13 (30) + 1$$

$$= 3.9 + 1$$

$$= 4.9 \text{ inches}$$

$$\text{or } 5.0 \text{ inches (rounded)}$$

* Note: For models 43-04F and 43-02C only

$$d \text{ inches} = 0.17 (D \text{ inches}) + 1$$

$$d \text{ mm} = 0.17 (D \text{ mm}) + 25$$

HIGH RESOLUTION

D (inches)	d (inches)	D (mm)	d (mm)
0.0	1.0	0	25
15	1.25	300	30
30	1.5	700	37
60	2.0	1,000	42
70	2.5	1,500	50
100	4.0	2,000	75
150	6.5	3,000	125
200	9.0	5,000	225
300	14.0	7,000	325
500	24.0	10,000	475
700	34.0	15,000	725
1,000	49.0	20,000	975

High Resolution Formula

If D > 60 inches or 1500mm then:
 d (inches) = 0.05 (D inches - 60) + 2
 d (mm) = 0.05 (D mm - 1500) + 50

If D < 60 inches or 1500mm then:

d (inches) = 0.17 (D inches) + 1
 d (mm) = 0.17 (D mm) + 25

Example:

If D = 90 inches, then d = 0.05 (90-60) + 2
 = 0.05 (30) + 2
 = 1.5 + 2
 = 3.5 inches

VERY HIGH RESOLUTION

D (inches)	d (inches)	D (mm)	d (mm)
8.0	0.3	203	7.6
15.0	1.0	381	25.4
25.0	2.0	635	50.8
35.0	3.0	889	76.2
45.0	4.0	1,143	101.6

Very High Resolution Formula

If D > 8 inches or 203mm then:
 d (inches) = 0.1 (D inches - 8) + 0.3
 d (mm) = 0.1 (D mm - 203) + 8

Note: for sensors with water-cooled castings, multiply spot size (d) from table or formula by 1.1

Example: If "d" is 8.2 inches per table or diagram, then "d" for water-cooled casting is
 $d = 8.2 \times 1.1 = 9.02$ inches

Model Identification Chart

The 8-digit model number represents the specifications for a specific instrument. Example: Model 44-05F-0-0-0 describes a model 44 series unit (8 to 14 microns); a temperature range of -17 to 260°C (0 to 500°F); standard optical resolution; 4 to 20 mA linear output; and a standard enclosure.

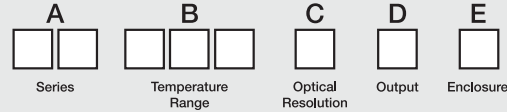

BLOCK A: Series Designation

22 = 22 series 8 to 14μ (microns)
 43 = 43 series 3.43μ (microns)
 44 = 44 series 8 to 14μ (microns)

45 = 45 series 3.7 to 4.0μ (microns)

46 = 46 series 2.0 to 2.6μ (microns)

47 = 47 series 4.8 to 5.2μ (microns)

48 = 48 series 7.5 to 8.5μ (microns)

BLOCK B: Series Designation

22 series (8 to 14μ)

02F = 0 to 200°F

05F = 0 to 500°F

10F = 0 to 1000°F

01C = 0 to 100°C

02C = 0 to 250°C

06C = 0 to 600°C

52F = -50 to 200°F***

51C = -50 to 100°C***

45 series (3.7 to 4.0μ)

15F = 500 to 1500°F

25F = 500 to 2500°F

08C = 300 to 800°C

13C = 300 to 1300°C

46 series (2.0 to 2.6μ)

10F = 500 to 1000°F**

14F = 600 to 1400°F

06C = 250 to 600°C**

08C = 350 to 800°C

47 series (4.8 to 5.2μ)

10F = 200 to 1000°F**

15F = 500 to 1500°F

25F = 500 to 2500°F

06C = 100 to 600°C**

08C = 300 to 800°C

13C = 300 to 1300°C

44 series (8 to 14μ)

02F = 0 to 200°F

05F = 0 to 500°F

10F = 0 to 1000°F

01C = 0 to 100°C

02C = 0 to 250°C

06C = 0 to 600°C

52F = -50 to 200°F***

51C = -50 to 100°C***

48 series (7.5 to 8.5μ)

06F = 0 to 600°F**

15F = 500 to 1500°F

25F = 500 to 2500°F

03C = 0 to 300°C**

08C = 300 to 800°C

13C = 300 to 1300°C

BLOCK C: Optical Resolution****

0 = Standard

1 = High

2 = Very high

BLOCK D: Output

0 = 4 to 20 mA dc

1 = 4 to 20 mA dc with peak picker (standard on 22 series)

BLOCK E: Enclosure

0 = Standard

1 = Water-cooled with air purge

* Minimum response time of 10 seconds for target temperature between 50 to 150°C (120 to 300°F). Minimum emissivity of 0.9 and sensing head ambient temperature of 10 to 45°C (50 to 113°F).

** "High" resolution version may require slower response time settings.

*** Standard resolution only.

**** "High" resolution and "Very High" resolution not available in 22 series or 43 series models.

The Worldwide Leader in Noncontact Temperature Measurement

IRCON, Inc.

Worldwide Headquarters

Santa Cruz, CA USA

Tel: 1 800 227 8074 (USA and Canada, only)

1 831 458 3900

info@ircon.com

European Headquarters

Berlin, Germany

Tel: 49 30 4 78 00 80

France

Tel: 0800 888 244

United Kingdom

Tel: +44 1908 630 800

China Headquarters

Beijing, China

Tel: 8610 6438 4691

To find an IRCON office near you, please visit www.ircon.com

Worldwide Service

IRCON offers services, including repair and calibration.

For more information, contact your local office or e-mail info@ircon.com

www.ircon.com



Raytek is an ISO 9001 certified company

© 2008 IRCON, Inc. (3309369 Rev G) 11/2008
 The IRCON logo and Modline are registered trademarks of IRCON, Inc.
 Specifications subject to change without notice.