

male header

87P261T1K



87P261T9G



technical data

male header

contact material : brass
insulator : nylon 66
Flammability : UL 94V-2

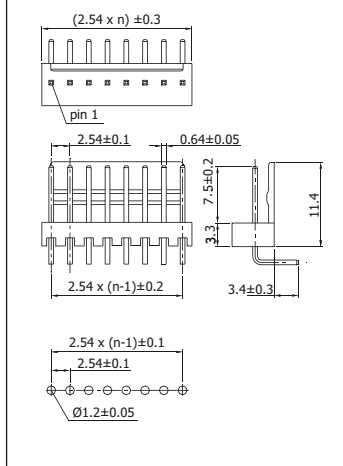
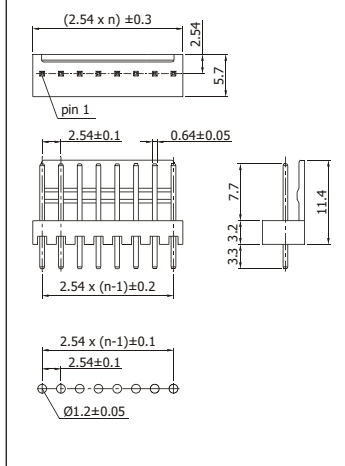

available pole no.: 02 to 15

available pole no.: 02 to 15

housing and terminal

87H261X1G



87C26FK-R50



technical data

housing

insulator : nylon 66
flammability : UL 94V-2

terminal

AWG : #22 - #28
contact material : phosphor bronze
packing : reel

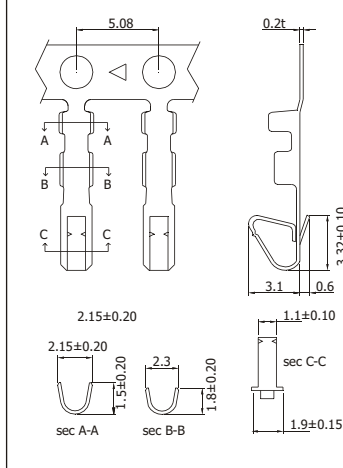
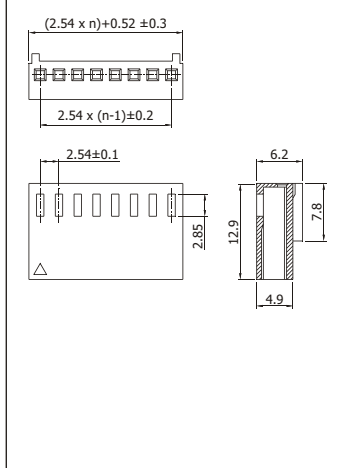

available pole no.: 02 to 15

packing unit: 10,000 pcs

electrical data

dielectric withstanding : 1000V AC / 1 min.
current rating : 3A max
insulation resistance : 1000 Meg Ohm min
contact resistance : 20 milli Ohm max
operating temperature : -25°C to +85°C

plating

50= tin

locating peg

X=without

place pad

Y=without, P=with

possible packing

L=loose, T=tube, R=reel

order code

header -

06 -

X

L

Y -

50

housing -

06 -

L

terminal -

R

50

series-no.

poles

locating peg

packing

place pad

plating

other dimensions / materials are available, please contact us